

# Resilient Processing Platform for 6G Mobile Networks

Marko Andjelkovic, Junchao Chen, Rizwan Tariq Syed, Fabian Vargas, Markus Ulbricht  
IHP, Im Technologiepark 25, Frankfurt (Oder), Germany



## MOTIVATION

- Reliability is important requirement for 6G communication networks.
- Modern integrated circuits may experience transient and permanent faults, which may affect their functionality.
- A common approach is to apply reconfigurability and on-chip sensing.
- Based on sensor information, the system can be reconfigured to achieve the required reliability.

## GOALS

- Within the Open6GHub project, IHP is developing a reconfigurable (self-adaptive) quad-core processing platform with on-chip sensing.
- In this work, initial designs for 4 sensors are presented: multipurpose (aging and soft error) sensor, glitch filter and detector, temperature sensor, and voter as a detector of transient and permanent faults.
- All sensors will be implemented on FPGA, and integrated in the resilient processing platform.

## RESILIENT PROCESSING PLATFORM

- Intended to serve as a central processing element in a 6G communication network node.
- Self-adaptive quad-core RISC-V platform based on extension of PULPissimo platform.
- Custom-designed neural network accelerator for processing data from external sensor.
- Supports three operating modes: high-performance, fault-tolerant and de-stress (low power).
- On-chip reliability sensors for monitoring the system's operating parameters (e.g. temperature) and detection of transient and permanent faults.
- Framework Controller is a custom-designed unit that performs system reconfiguration (selection of operating modes) based on sensing information.

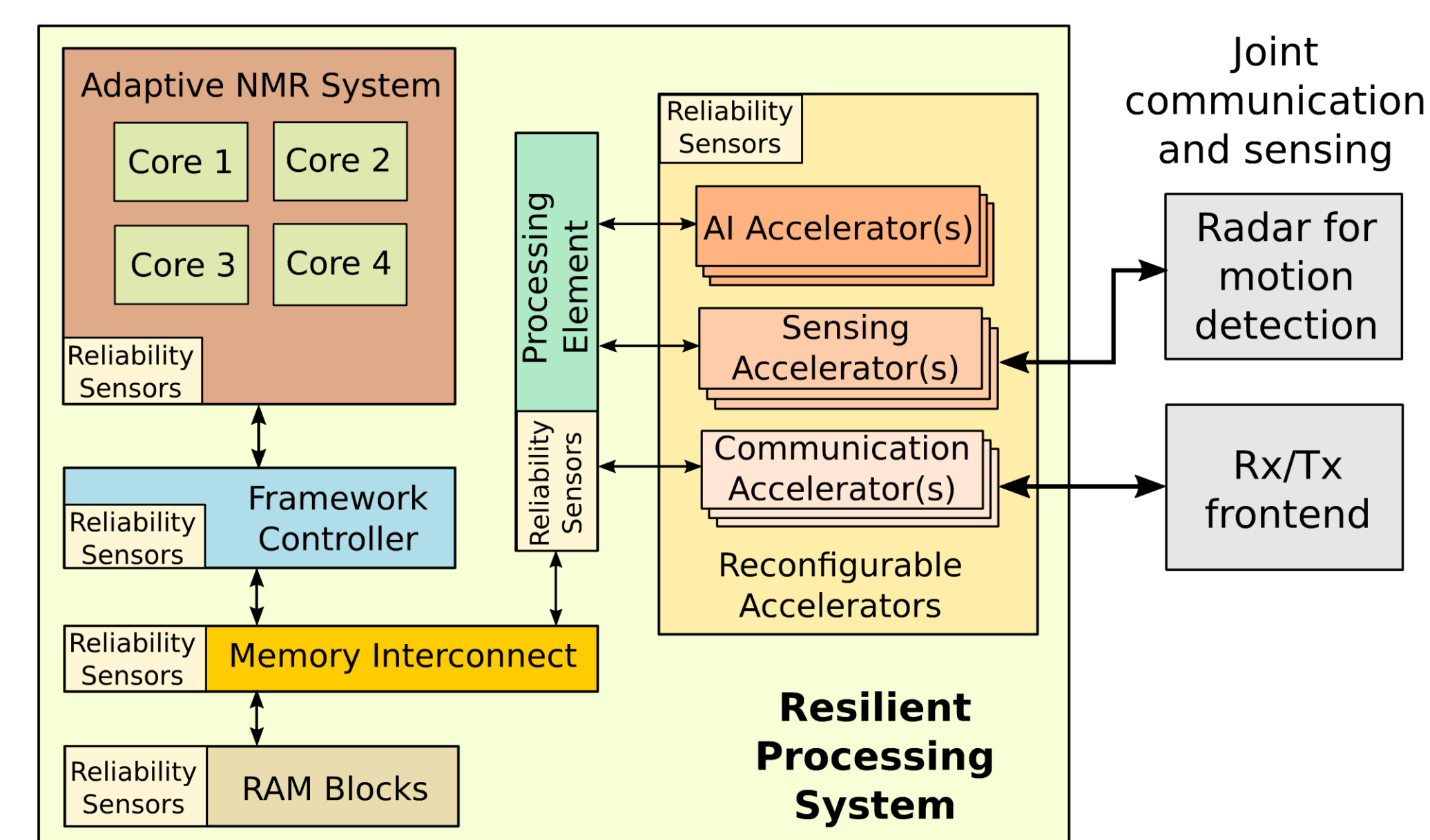

## SELF-CHECKING SENSORS

- Transient and permanent faults may occur in the sensors, resulting in erroneous reading.
- Sensors are designed with self-checking functionality, providing two types of information: (1) information read by the sensor, and (2) information on errors in the sensor.
- For each sensor, a Sensor Management Unit is used to collect all information and perform initial processing.
- Data from all sensors is collected by the Framework Controller, which decides on the required actions.
- If an erroneous sensor is detected, it can be replaced with a redundant sensor or restarted if possible.

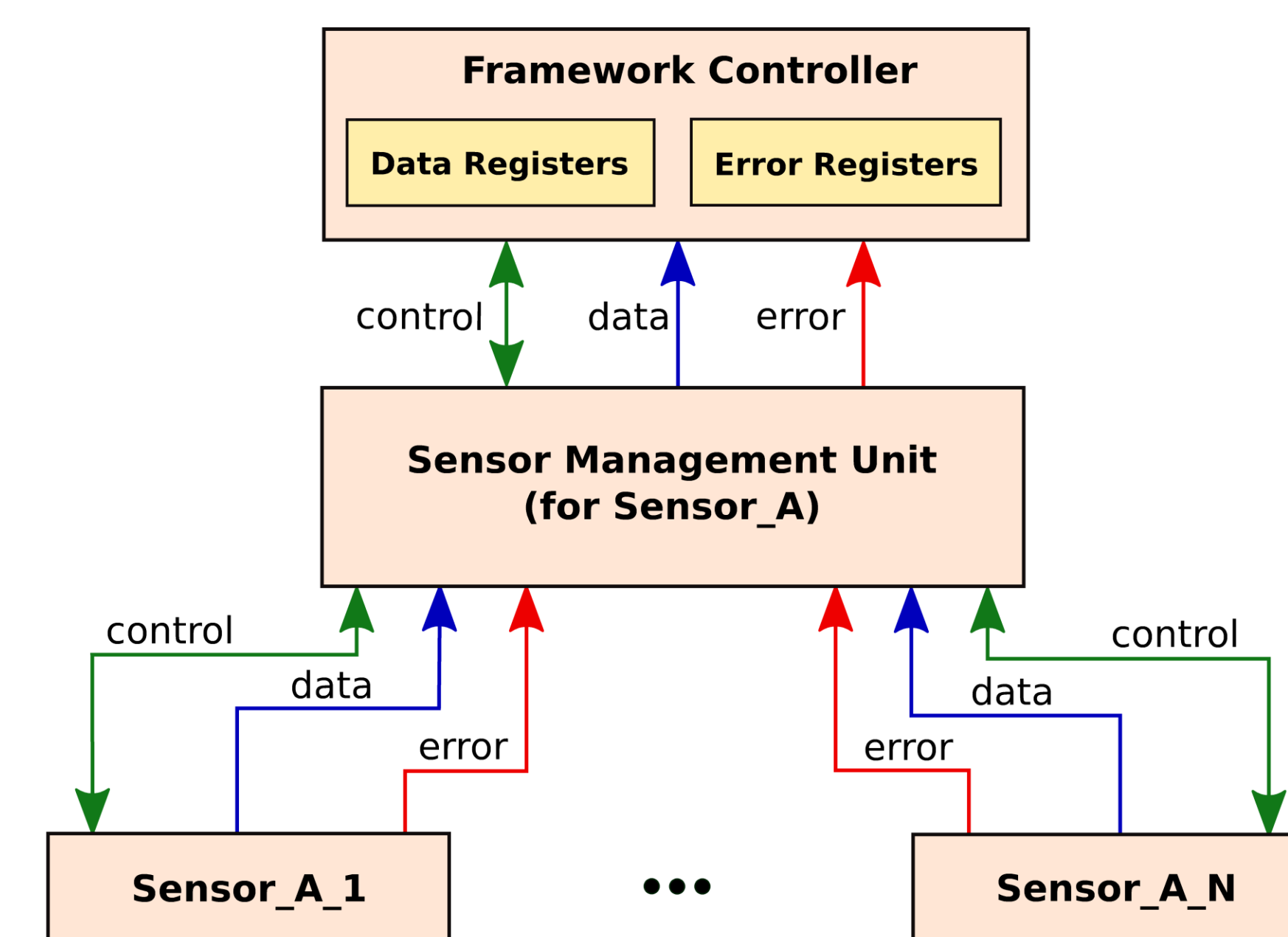

## ON-CHIP SENSORS FOR SYSTEM STATUS MONITORING

### Multipurpose sensor for monitoring aging and soft errors

- Monitors aging evolution across critical paths and detects soft errors in respective flip-flops.
- Three clock signals are used to control the sensor and select between aging and soft error detection modes.
- Low overhead – only two additional flip-flops and XOR gate.

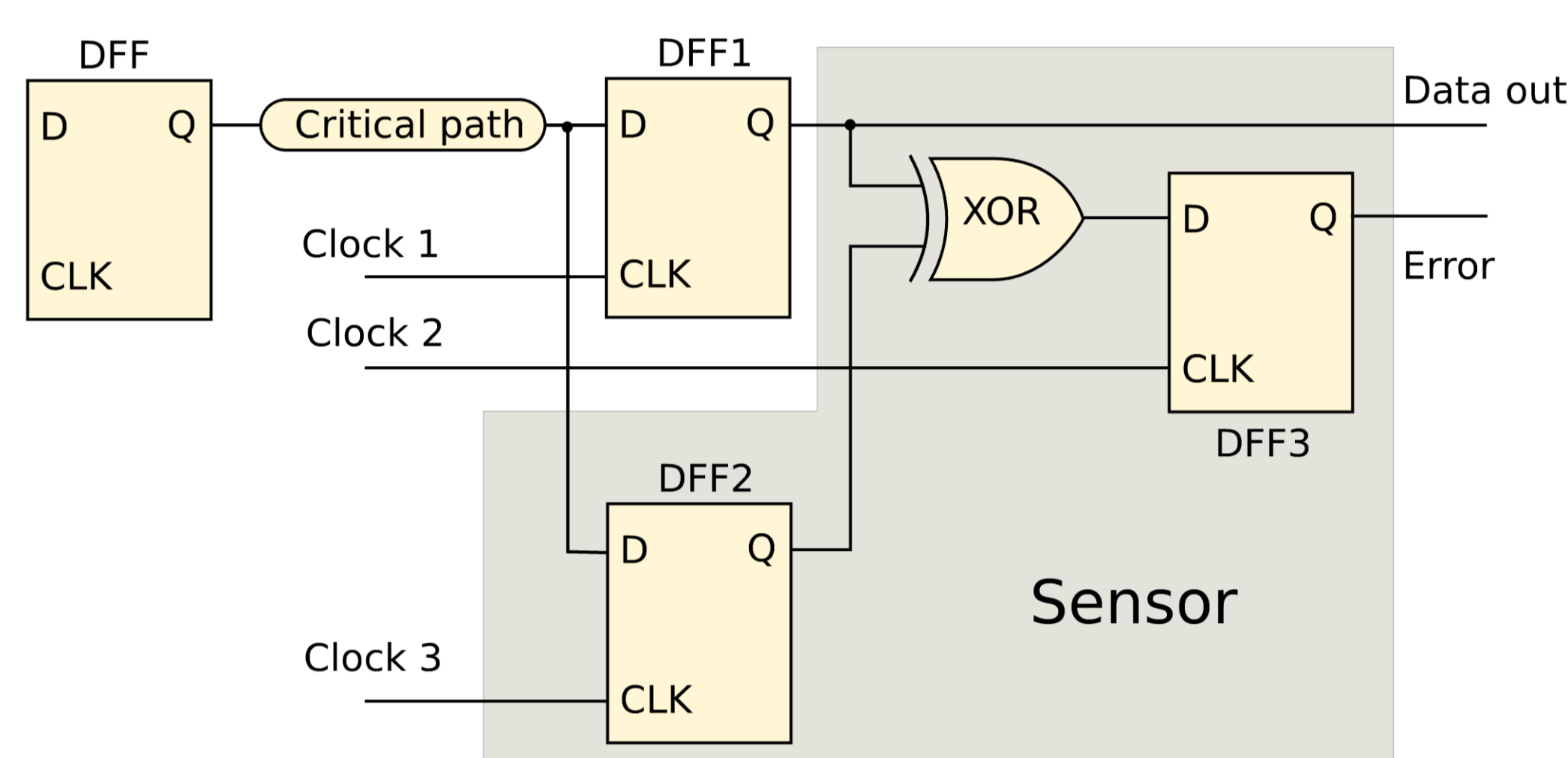

### Voltage glitch filter and detector for data/control lines

- Filtering of voltage glitches in data and control lines (e.g., clock, reset), and storing the number of detected glitches.
- Glitch filtering is done with a delay line and a C-element, while self-checking counters are used to store the glitch count.
- Glitches with duration from tens to hundreds of ps can be filtered.

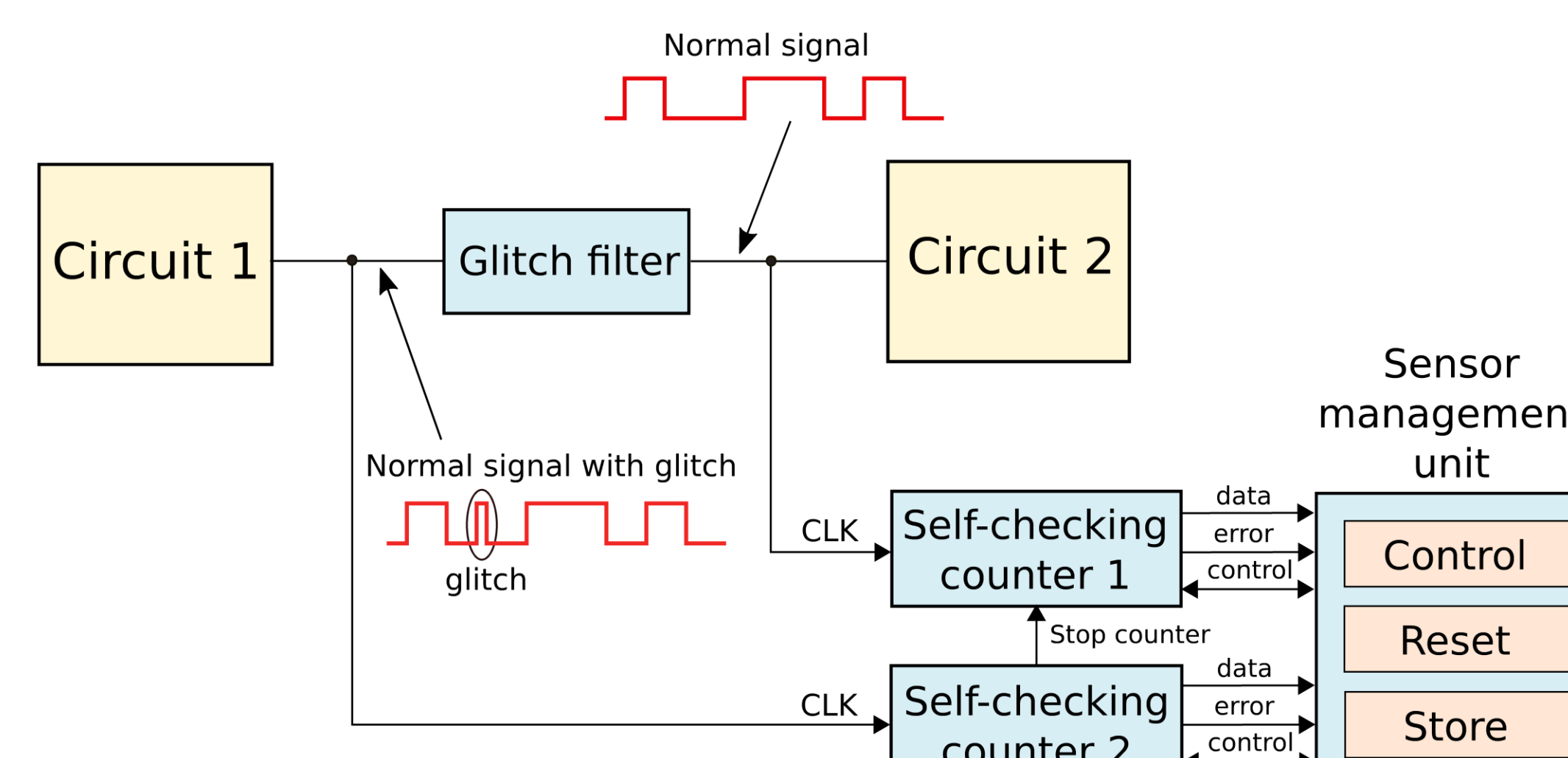

### Voter for detection of transient and permanent faults

- Compares the outputs of two or more identical functional units and stores the number and type of detected faults.
- Generates error indication whenever any input mismatch is detected.

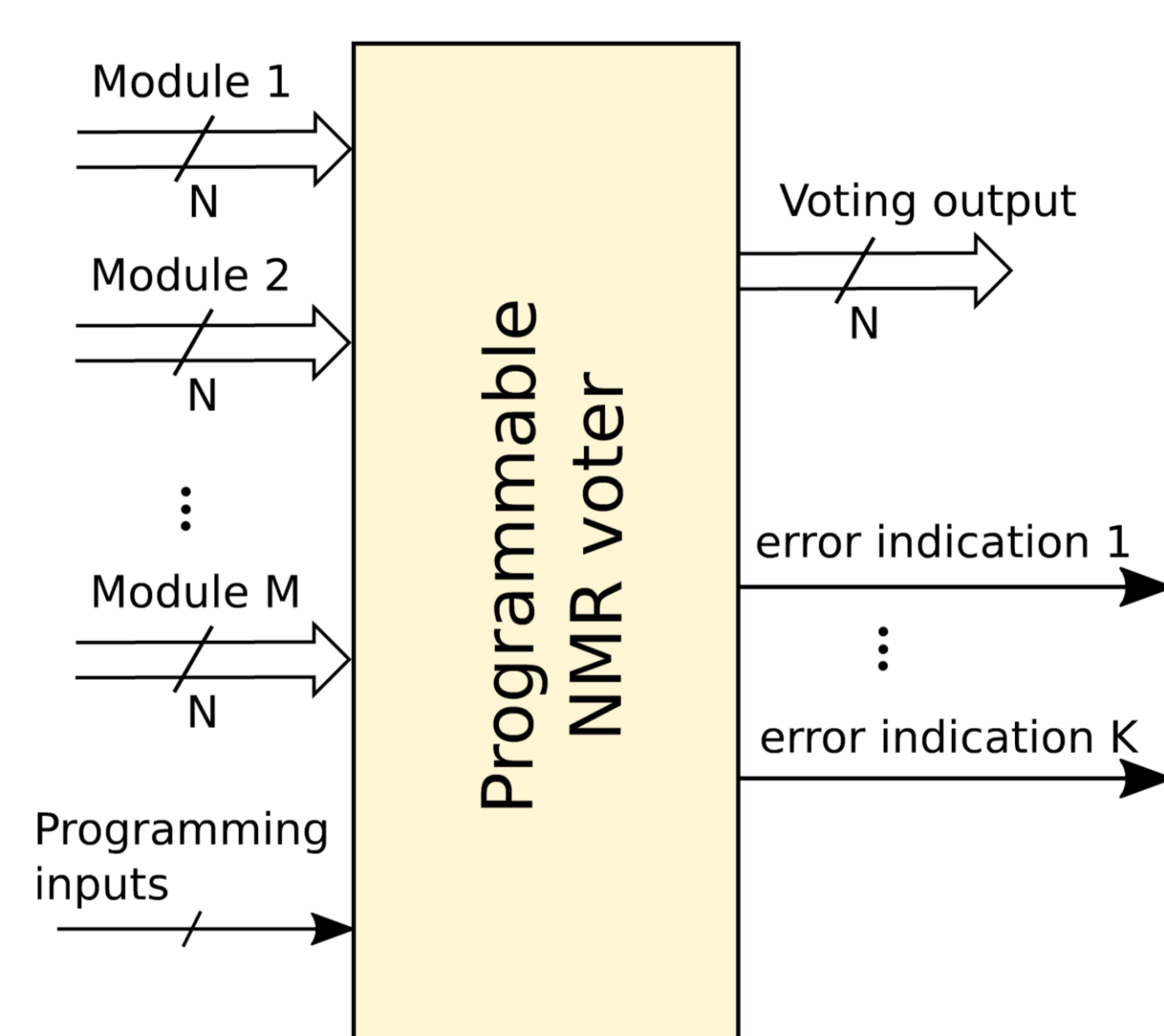

### Digital temperature monitor

- Multiple sensors enable temperature monitoring across the die.
- Based on ring oscillators, providing temperature reading in terms of oscillator frequency (number of oscillators).

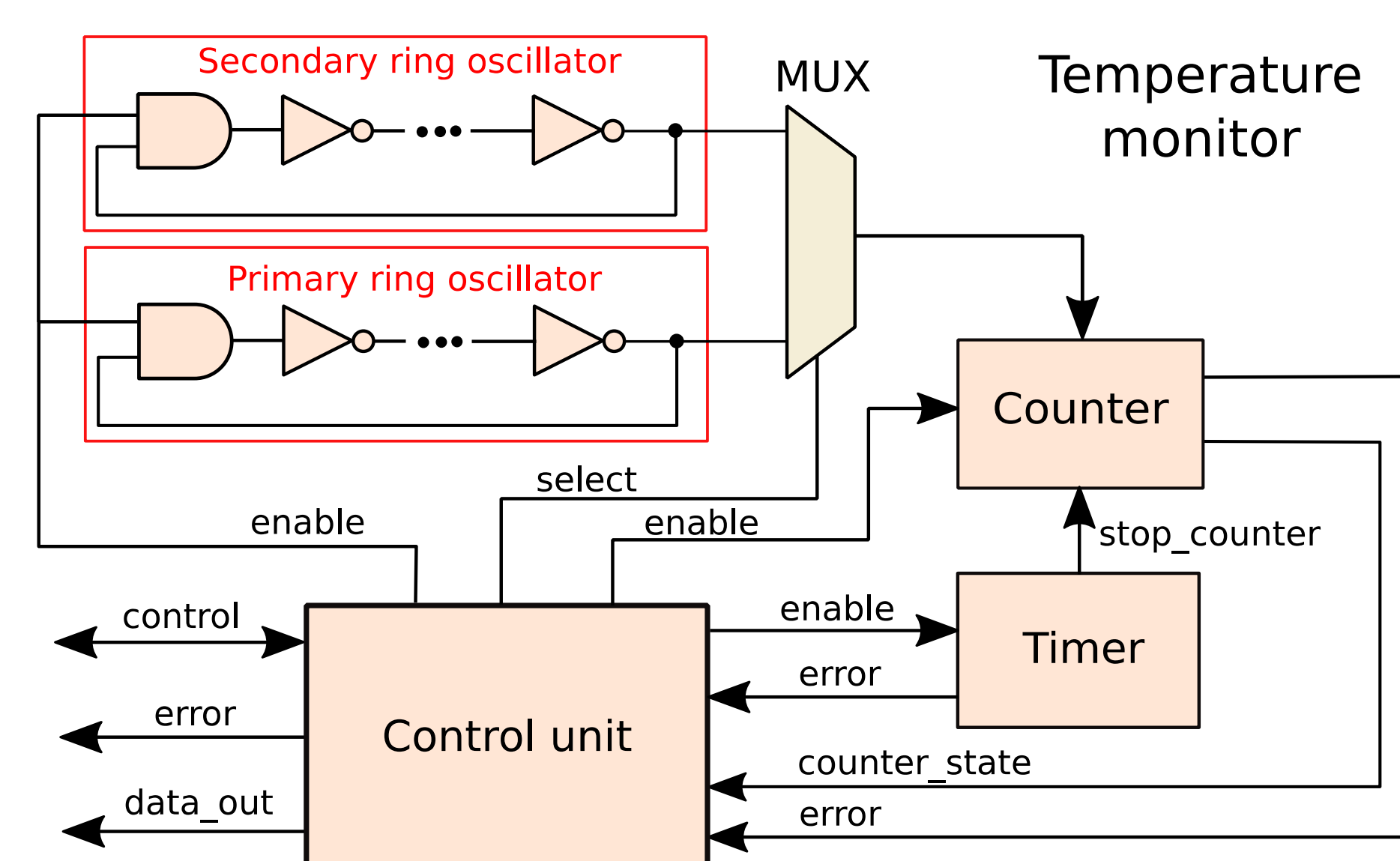

**Funding:** This work is funded by the Federal Ministry of Education and Research of Germany (BMBF) within the "Open6GHub" project (grant number: 16KISK009).

